

**Ground Floor level**  
SCALE 1:100 on A3

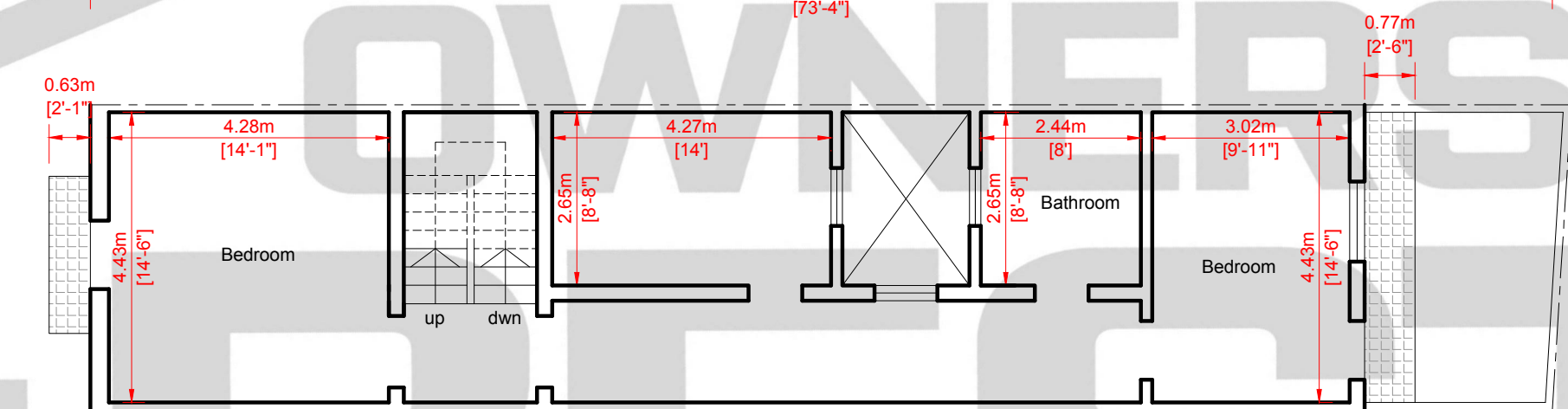

**First floor level**  
SCALE 1:100 on A3

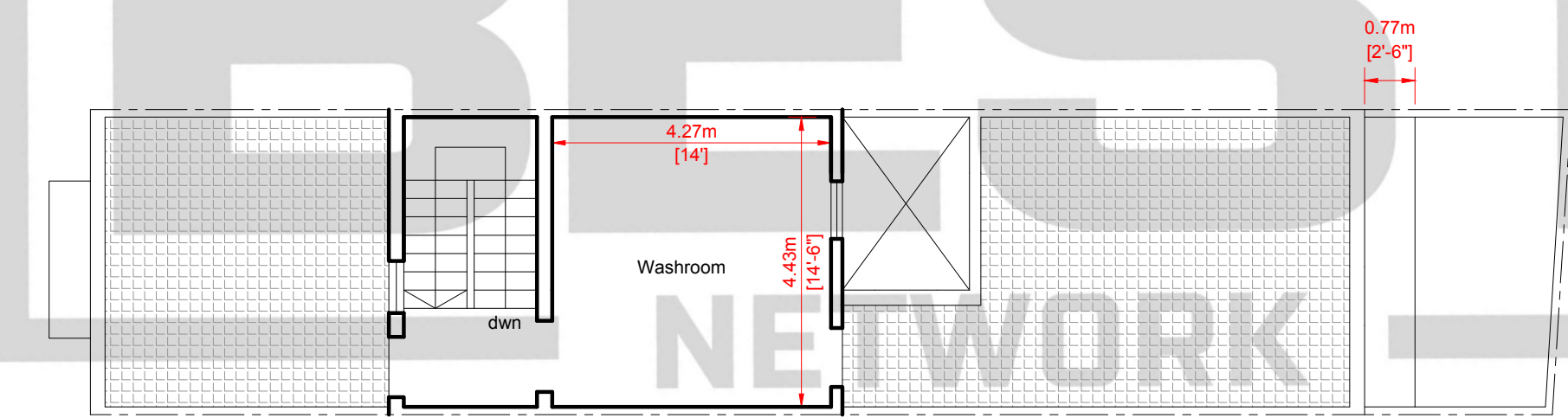

**Second floor level**  
SCALE 1:100 on A3

Disclaimer: These preliminary drawings are the property of Owners Best and the information provided is only for indicative guidance on the present property layout.

**Owners Best**

Property Address: Triq Santa Tereza, Hal Tarxien  
Reference: 700308

Total Internal area: c. 203.3 sq m    External area: c. 24.9 sq m  
Total Ground Floor area: c. 104.9 sq m    Date: 12/05/2017

